



□200mm



Material: Steel

Dimension (units:mm)

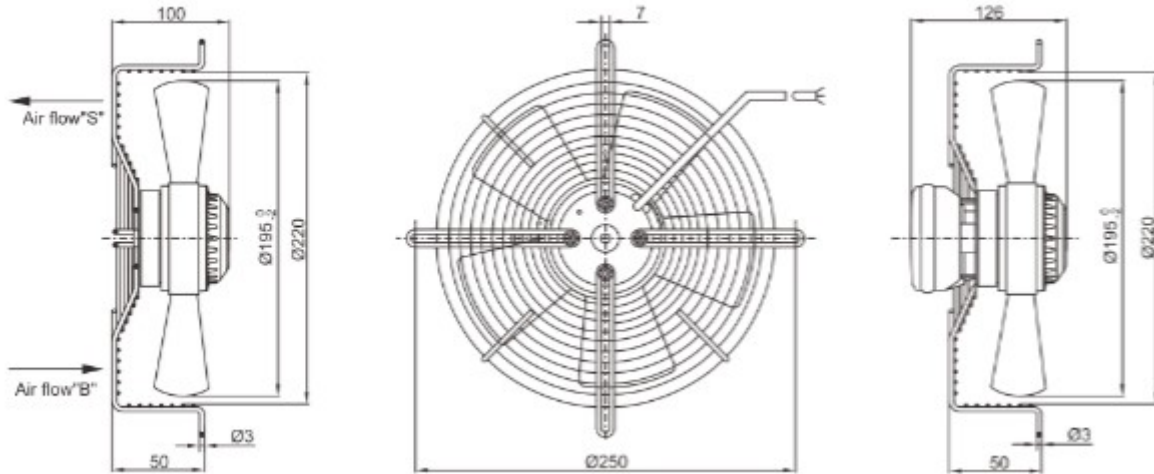

Characteristic Curves

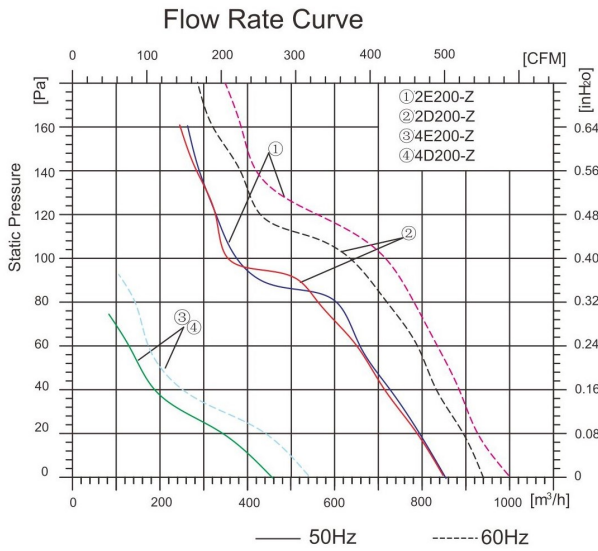

NO.	Pst (Pa)	Fre (Hz)	P1 (W)	I (A)
①	20	50/60	70/75	0.35/0.33
	80	50/60	73/81	0.36/0.35
②	20	50/60	61/73	0.12/0.12
	80	50/60	64/79	0.13/0.13
NO.	Pst (Pa)	Fre (Hz)	P1 (W)	I (A)
③	10	50/60	23/25	0.11/0.12
	40	50/60	24/25	0.11/0.13
④	10	50/60	47/37	0.15/0.12
	40	50/60	47/38	0.15/0.12

SPECIFICATION

Model	Voltage (V)	Freq. (Hz)	Current (A)	Power (W)	Speed (RPM)	Air Flow (m3/h)	Noise (dB)	Weight (kg)
2E200Z	230	50/60	0.39/0.45	80/95	2700/3200	870/1000	60/65	1.9
2D200Z	380	50/60	0.13/0.15	70/90	2650/3000	870/1000	60/64	1.9
4E200Z	230	50/60	0.15/0.18	29/38	1420/1600	450/560	48/51	1.9
4D200Z	380	50/60	0.12	50/90	1450/1750	450/530	48/53	1.9