



□500mm



Material: Steel **Weight:** 9.5kg / PC

Dimension (units:mm)

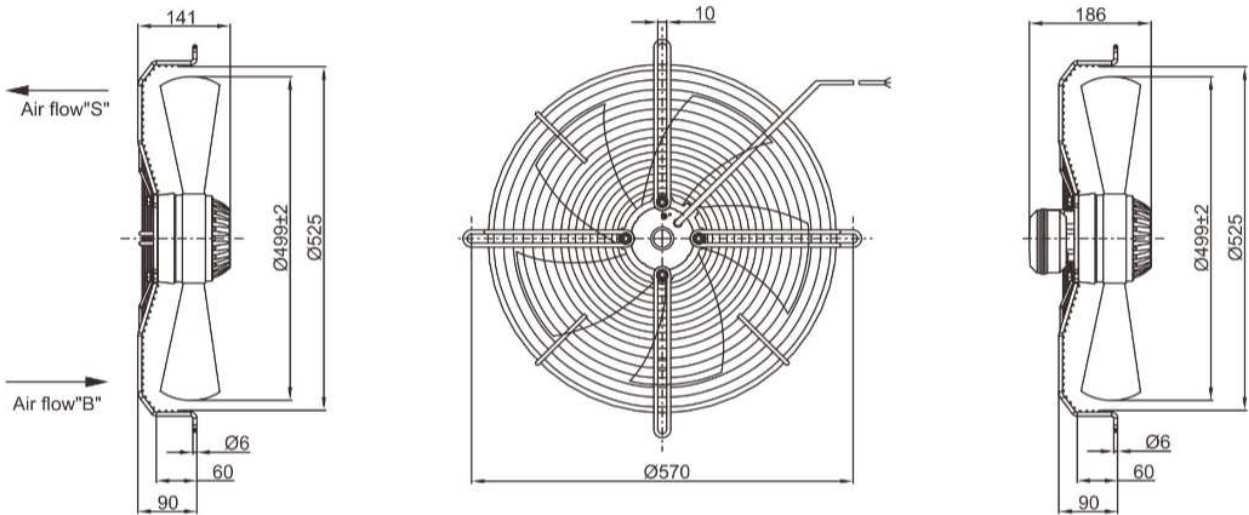

Characteristic Curves

NO.	Pst (Pa)	Fre (Hz)	P1 (W)	I (A)
①	20	60	520	2.43
	100	60	557	2.53
②	20	60	425	0.77
	100	60	520	0.89

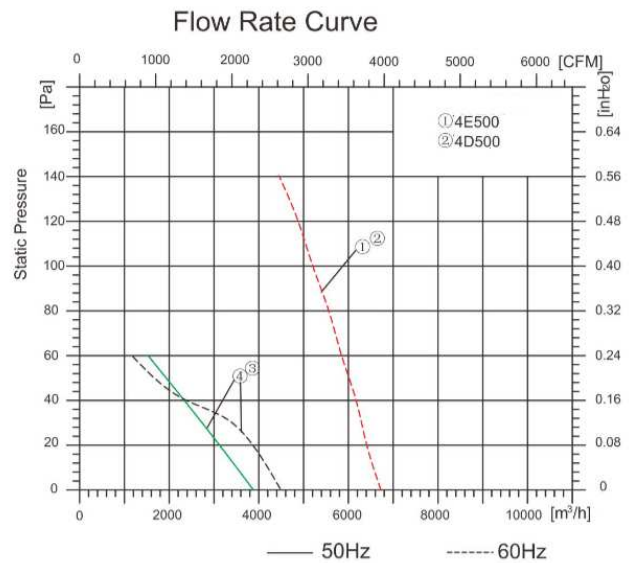

SPECIFICATION

Model	Voltage (V)	Freq. (Hz)	Current (A)	Power (W)	Speed (RPM)	Air Flow (m3/h)	Max Environmental temperature °C	Noise (dB)
4E500Z	230	50	2.5	550	1590	6750	50	76
4D500Z	380	50	0.91/0.93	450/500	1320/1550	5850/6700	50	76
6E500Z	230	50	1.15/1.4	230/320	920/1050	5200/6150	50	67/69
6D500Z	380	50	0.78/0.65	250/320	920/1060	5200/6150	50	67/69

AC Axial Fan