



□550mm



**Material:** Steel **Weight:** 10.5kg / PC

Dimension (units:mm)

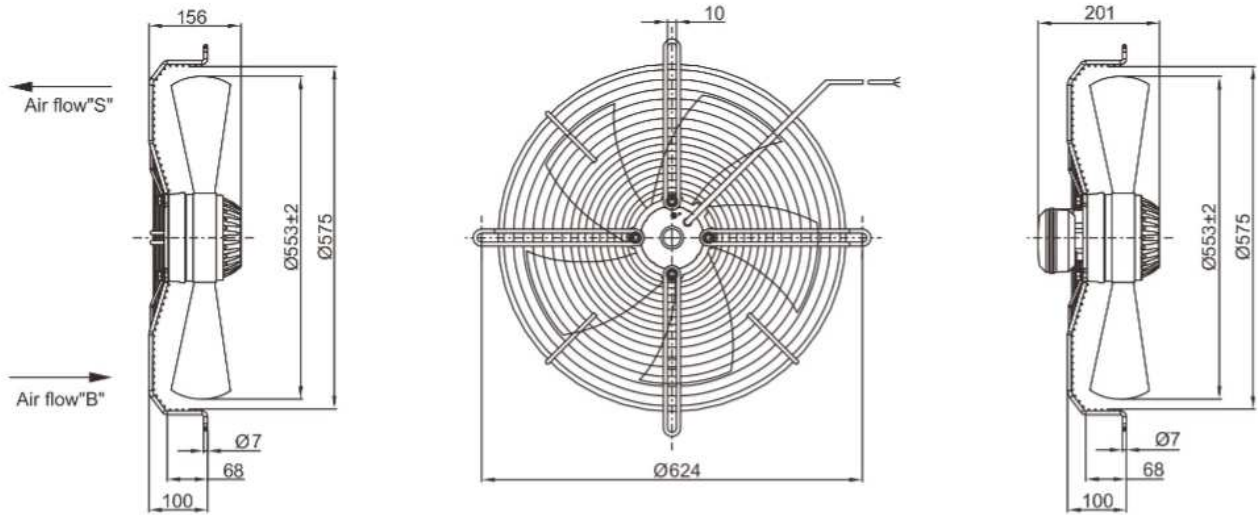

Characteristic Curves

| NO. | Pst (Pa) | Fre (Hz) | P1 (W) | I (A) |
|-----|----------|----------|--------|-------|
| ①   | 20       | 60       | 633    | 2.83  |
|     | 100      | 60       | 706    | 3.07  |
| ②   | 20       | 60       | 645    | 1.09  |
|     | 100      | 60       | 753    | 1.25  |

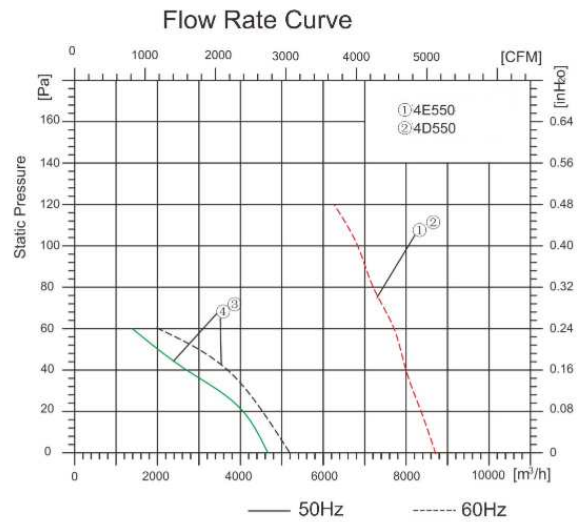

**SPECIFICATION**

| Model  | Voltage (V) | Freq. (Hz) | Current (A) | Power (W) | Speed (RPM) | Air Flow (m3/h) | Max Environmental temperature °C | Noise (dB) |
|--------|-------------|------------|-------------|-----------|-------------|-----------------|----------------------------------|------------|
| 4E550Z | 230         | 50         | 2.45        | 550       | 1310        | 8500            | 50                               | 76         |
| 4D550Z | 380         | 50/60      | 1.1/1.2     | 600/650   | 1320/1500   | 8650            | 50                               | 78         |
| 6E550Z | 230         | 50/60      | 1.68/1.83   | 330/420   | 910/1080    | 6200/7100       | 50                               | 67/68      |
| 6D550Z | 380         | 50/60      | 0.87        | 330/410   | 900/1070    | 6200/7100       | 50                               | 67/68      |

AC Axial Fan