



□ 600mm



Material: Steel **Weight:** 15kg / PC

Dimension (units:mm)

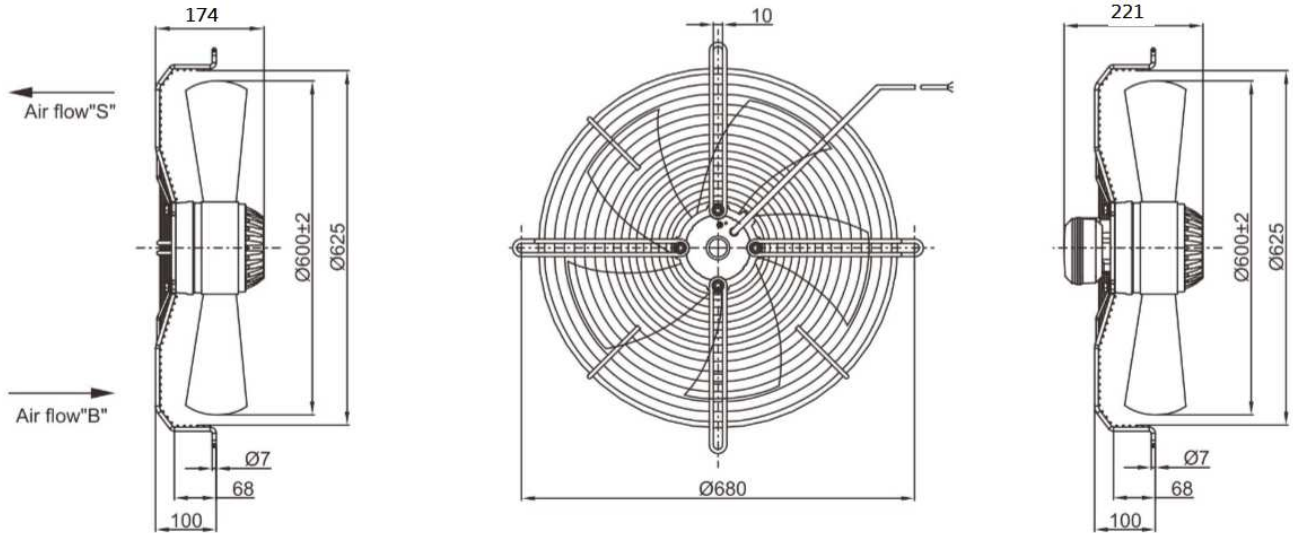

Characteristic Curves

NO.	Pst (Pa)	Fre (Hz)	P1 (W)	I (A)
①	20	60	877	3.86
	80	60	951	4.17
②	20	60	853	1.60
	100	60	951	1.73

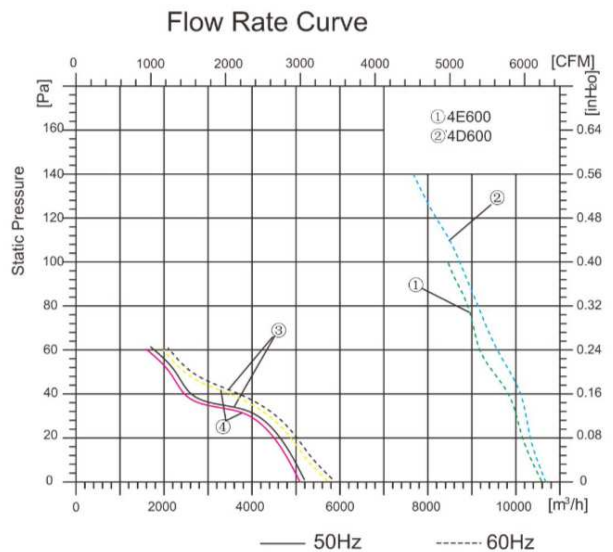

SPECIFICATION

Model	Voltage (V)	Freq. (Hz)	Current (A)	Power (W)	Speed (RPM)	Air Flow (m3/h)	Max Environmental temperature °C	Noise (dB)
4E600Z	230	50	3.5	810	1315	10300	50	76
4D600Z	380	50/60	1.67/1.78	850/950	1330/1580	10800	50	79
6E600Z	230	50/60	2.2/2.8	500/600	900/1030	7500/9250	50	70/71
6D600Z	380	50/60	1.57/1.3	550/600	920/1070	8100/9500	50	70/72

AC Axial Fan