



□650mm



Material: Steel **Weight:** 18kg / PC

Dimension (units:mm)

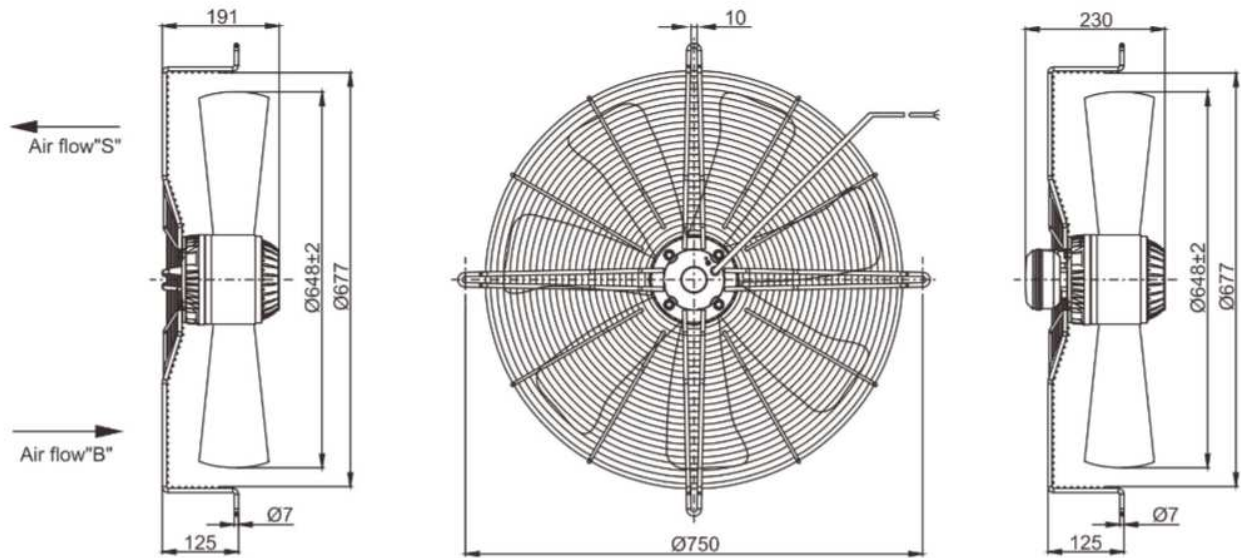

Characteristic Curves

NO.	Pst (Pa)	Fre (Hz)	P1 (W)	I (A)
①	20	50	960	2.17
	120	50	1113	2.30
②	20	50	950	4.35
	120	50	1100	5.03

Flow Rate Curve

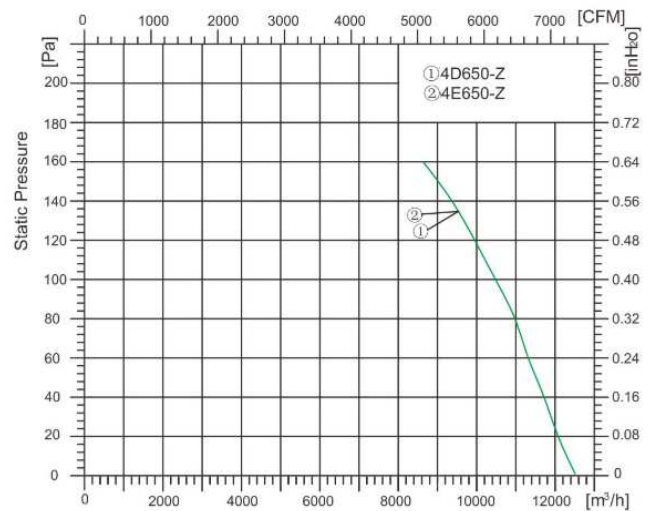

SPECIFICATION

Model	Voltage (V)	Freq. (Hz)	Current (A)	Power (W)	Speed (RPM)	Air Flow (m3/h)	Max Environmental temperature °C	Noise (dB)
4D650Z	400	50	2.3	1100	1330	12500	60	83
4E650Z	230	50	5.1	1100	1330	12500	60	83