



□710mm



Material: Steel **Weight:** 29kg / PC

Dimension (units:mm)

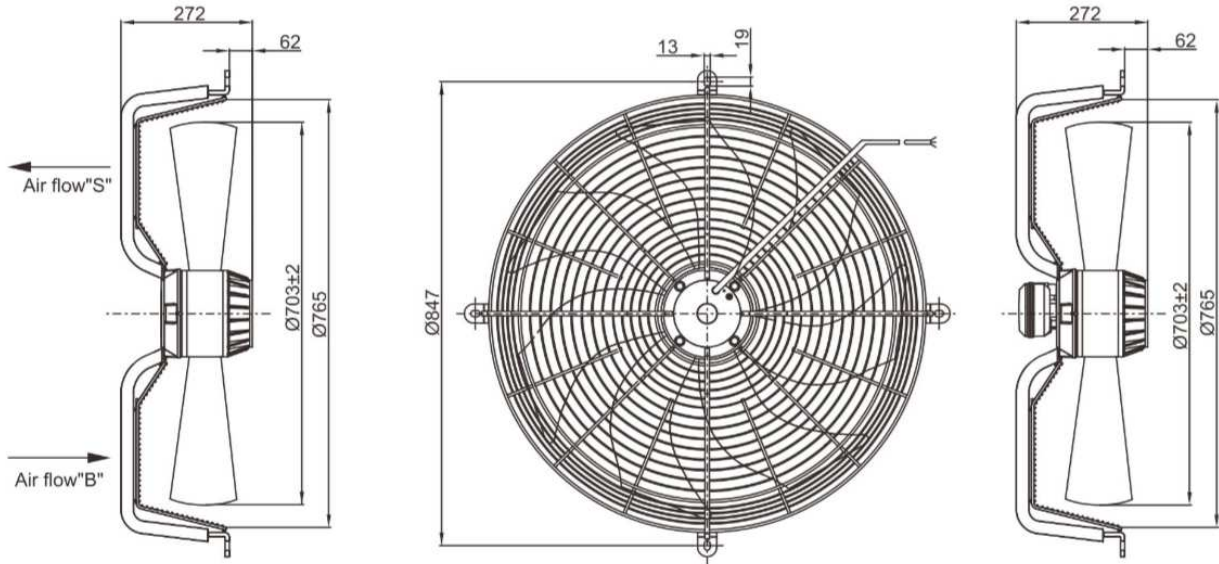

Characteristic Curves

NO.	Pst (Pa)	Fre (Hz)	P1 (W)	I (A)
① Δ	40	50	980	2.12
	130	50	1103	2.35
① Y	30	50	680	1.17
	80	50	720	1.23
NO.	Pst (Pa)	Fre (Hz)	P1 (W)	I (A)
② Δ	40	60	1498	2.52
	130	60	1621	2.68
② Y	30	60	810	1.33
	80	60	850	1.28

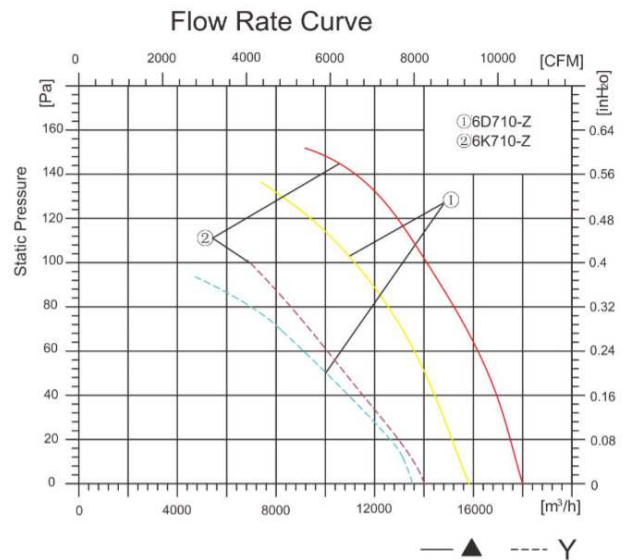

SPECIFICATION

Model	Voltage (V)	Freq. (Hz)	Current (A)	Power (W)	Speed (RPM)	Air Flow (m3/h)	Max Environmental temperature °C	Noise (dB)
6D710Z	400	50	2.35/1.2	1100/700	900/760	15800/13500	50	79/73
6K710Z	460	60	2.65/1.36	1600/950	1050/900	18000/14100	50	81/75

AC Axial Fan