



□910mm



Material: Steel **Weight:** 38kg / PC

Dimension (units:mm)

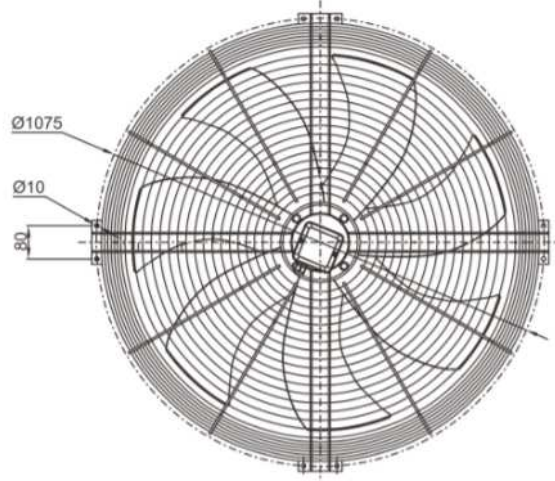
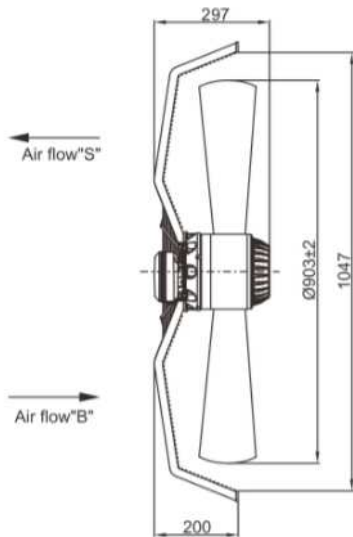

Characteristic Curves

NO.	Pst (Pa)	Fre (Hz)	P1 (W)	I (A)
△	50	50	2050	4.2
	235	50	2450	4.7
Y	60	50	1430	2.5
	120	50	1550	2.6

Flow Rate Curve

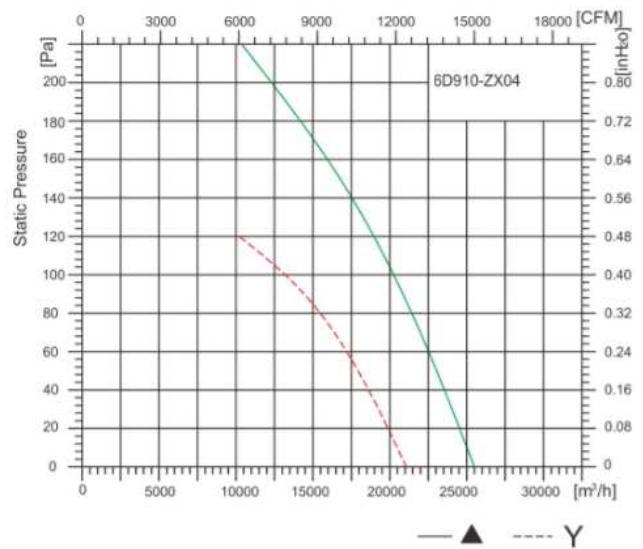

SPECIFICATION

Model	Voltage (V)	Freq. (Hz)	Current (A)	Power (W)	Speed (RPM)	Air Flow (m3/h)	Max Environmental temperature °C	Noise (dB)
6D910-ZX04	400	50	4.7/2.6	2450/1550	870/670	25500/21000	50	82/75

AC Axial Fan



□910mm



Material: Steel **Weight:** 42kg / PC

Dimension (units:mm)

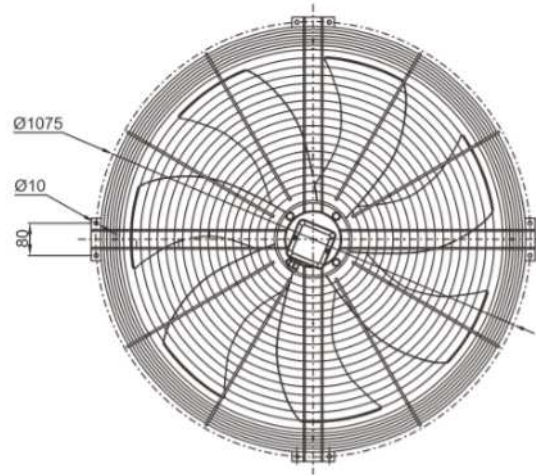
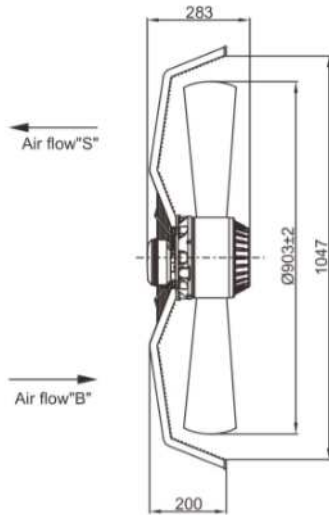

Characteristic Curves

NO.	Pst (Pa)	Fre (Hz)	P1 (W)	I (A)
①	50	50	2855	4.97
	120	50	3100	5.4

NO.	Pst (Pa)	Fre (Hz)	P1 (W)	I (A)
②	50	60	2694	4.53
△	150	60	3000	5.1
②	20	60	1950	3.1
Y	120	60	2100	3.6

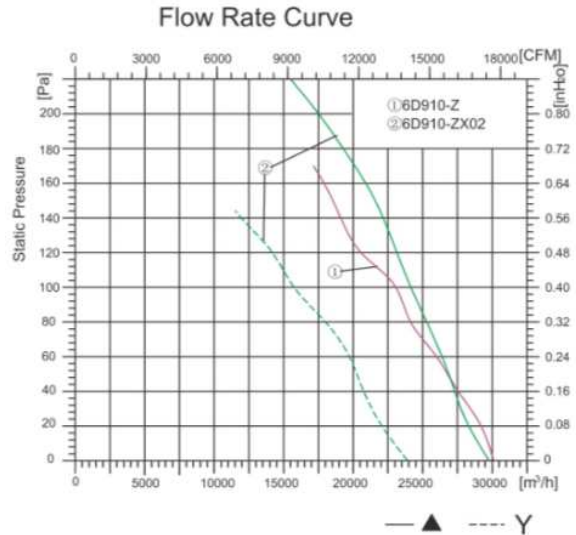

SPECIFICATION

Model	Voltage (V)	Freq. (Hz)	Current (A)	Power (W)	Speed (RPM)	Air Flow (m3/h)	Max Environmental temperature °C	Noise (dB)
6D910Z	400	50	5.4	3100	890	30000	60	82
6D910ZX02	400	60	5.1/3.4	3000/2000	1040/830	29000/24000	60	86/79