



□ 55x62x12 mm



Motor: DC single phase brushless motor

Material/Frame: PBT (94V-0); Impeller: PBT(94V-0)

Operation Temperature:

Two ball bearing -10°C ~ +70°C

FMB/Sleeve bearing -10°C ~ +50°C

Storage Temperature: -40°C ~ +80°C

Non-condensing environment

Weight: 35g / PC

Drawing:

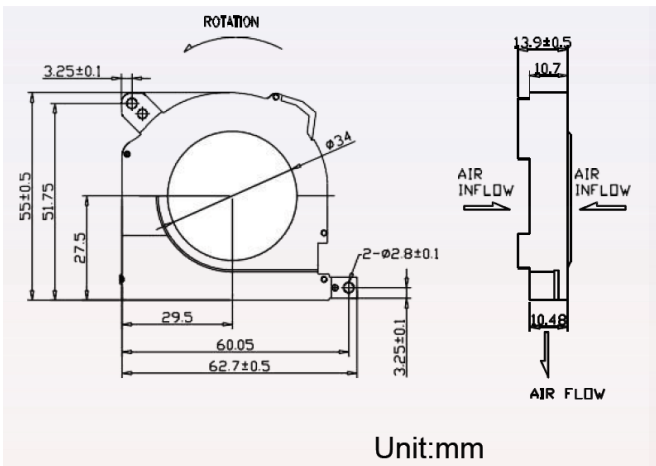

Characteristic Curves

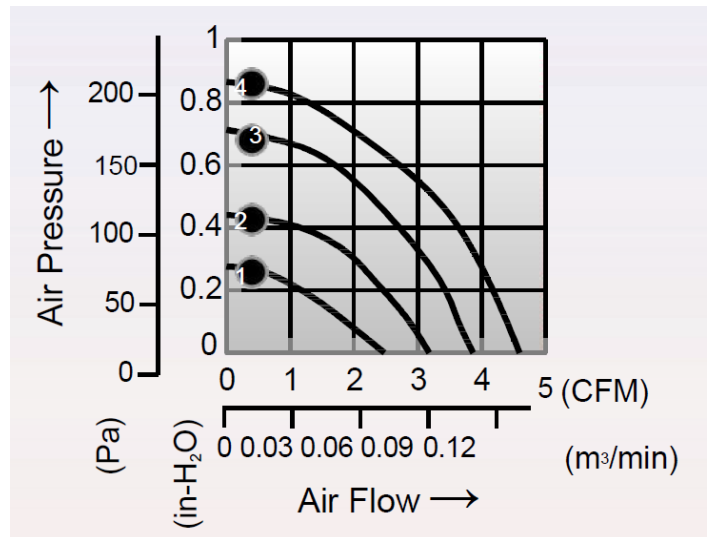

SPECIFICATION

Model	Voltage (V)	Operating Voltage Range(VDC)	Current (A)	Speed (RPM)	Air Flow (CFM)	Pressure (in-H ₂ O)	Noise (dB)
CDB055512LB	5	4.5 – 5.5	0.27	3900	3.5	0.33	27
CDB055512MB	5	4.5 – 5.5	0.33	4000	4.2	0.41	30
CDB055512HB	5	4.5 – 5.5	0.40	4900	5.1	0.56	33
CDB125512LB	12	7.0 – 13.2	0.16	3500	3.5	0.33	27
CDB125512MB	12	7.0 – 13.2	0.23	4000	4.2	0.41	30
CDB125512HB	12	7.0 – 13.2	0.33	4900	5.1	0.56	33