



# □ 60x60x25 mm

**Motor:** DC single phase brushless motor

**Material/Frame:** PBT (94V-0); Impeller: PBT(94V-0)

**Operation Temperature:**

Two ball bearing -10°C ~ +70°C

FMB/Sleeve bearing -10°C ~ +50°C

**Storage Temperature:** -40°C ~ +80°C

**Non-condensing environment**

**Weight:** 45g / PC

**Drawing:**

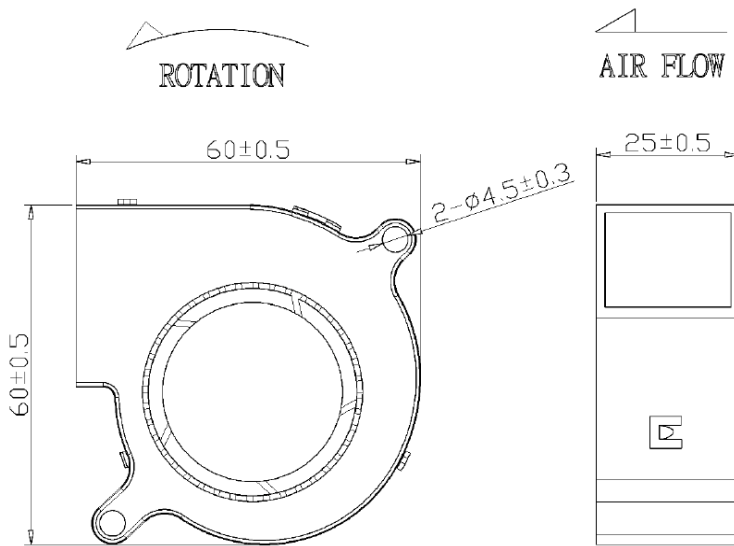

**Characteristic Curves**

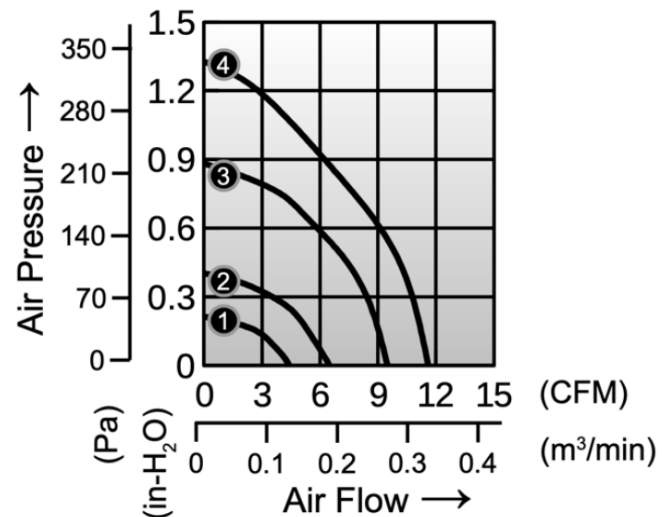

## SPECIFICATION

Model	Voltage (V)	Operating Voltage Range(VDC)	Current (A)	Speed (RPM)	Air Flow (CFM)	Pressure (in-H <sub>2</sub> O)	Noise (dB)
CDB126025IB	12	7.0 – 13.2	0.10	2500	5.6	0.21	24
CDB126025LB	12	7.0 – 13.2	0.25	3500	7.2	0.40	27
CDB126025MB	12	7.0 – 13.3	0.40	4500	10.5	0.75	41
CDB126025HB	12	7.0 – 13.4	0.50	5500	12.8	1.13	47