



□ 75x75x30 mm

Motor: DC single phase brushless motor

Material/Frame: PBT (94V-0); Impeller: PBT(94V-0)

Operation Temperature:

Two ball bearing -10°C ~ +70°C

FMB/Sleeve bearing -10°C ~ +50°C

Storage Temperature: -40°C ~ +80°C

Non-condensing environment

Weight: 100g / PC



Drawing:

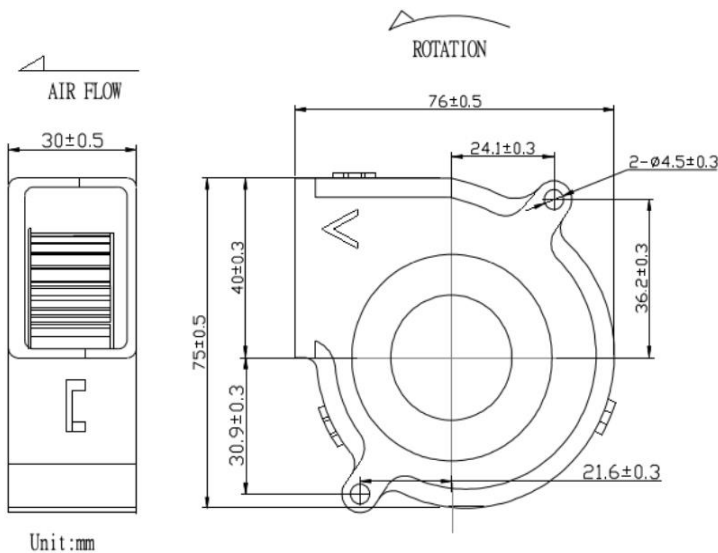

Characteristic Curves

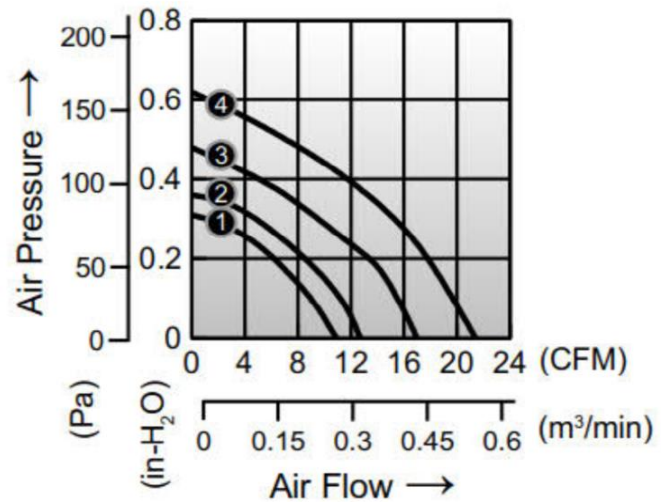

SPECIFICATION

| Model | Voltage (V) | Operating Voltage Range(VDC) | Current (A) | Speed (RPM) | Air Flow (CFM) | Pressure (in-H2O) | Noise (dB) |
|-------------|-------------|------------------------------|-------------|-------------|----------------|-------------------|------------|
| CDB127530JB | 12 | 7.0 – 13.2 | 0.24 | 2600 | 10.9 | 0.31 | 32 |
| CDB127530LB | 12 | 7.0 – 13.2 | 0.30 | 3000 | 12.7 | 0.36 | 41 |
| CDB127530MB | 12 | 7.0 – 13.2 | 0.38 | 3600 | 17.0 | 0.48 | 48 |
| CDB127530HB | 12 | 7.0 – 13.2 | 0.45 | 4000 | 21.4 | 0.62 | 51 |
| CDB247530JB | 24 | 14.0 – 26.4 | 0.13 | 2600 | 10.9 | 0.31 | 32. |
| CDB247530LB | 24 | 14.0 – 26.4 | 0.16 | 3000 | 12.7 | 0.36 | 41 |
| CDB247530MB | 24 | 14.0 – 26.4 | 0.22 | 3600 | 17.0 | 0.48 | 48 |
| CDB247530HB | 24 | 14.0 – 26.4 | 0.26 | 4000 | 21.4 | 0.62 | 51 |