

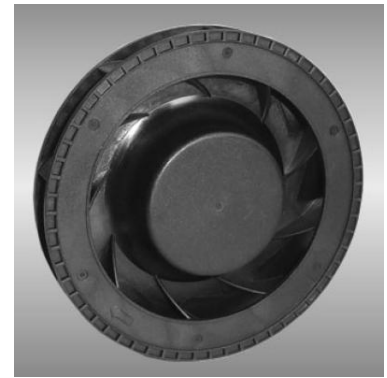

ø105X25 mm



Motor: DC single phase brushless motor
Material/Frame: Die cast aluminum (94V-0);
Impeller: Plastic(94V-0)
Bearing: Two ball precision bearing
Weight: 0.13kg / PC

Drawing

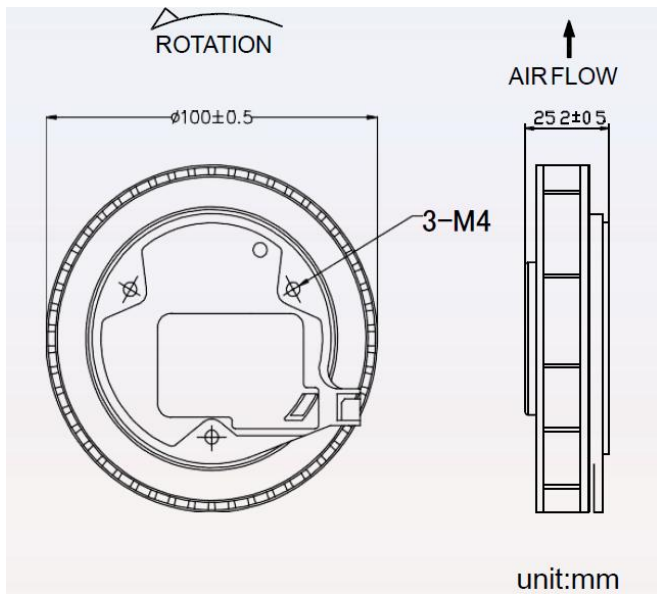

Characteristic Curves

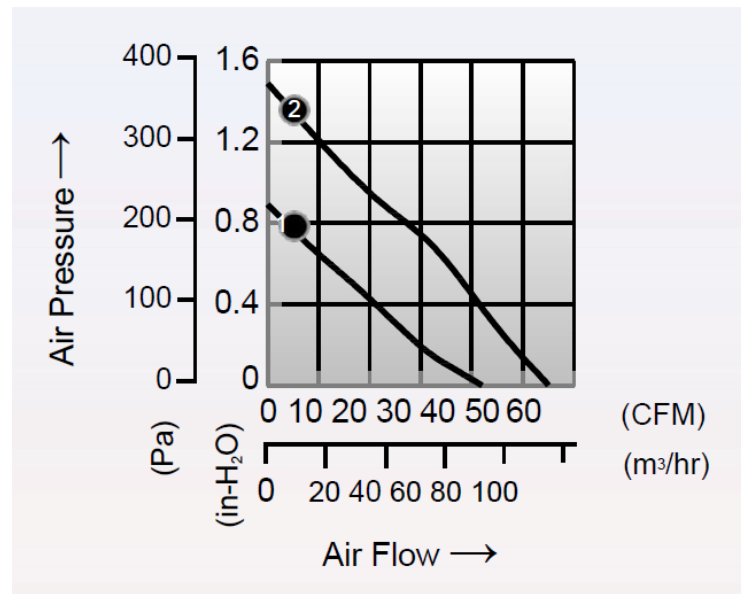

SPECIFICATION

Model	Voltage (V)	Current (A)	Speed (RPM)	Air Flow (CFM)	Pressure (in-H ₂ O)	Noise (dB)
CDC121025HB	12	0.5	4300	42	0.89	53
CDC121025XB	12	0.1	5300	55	1.49	58