

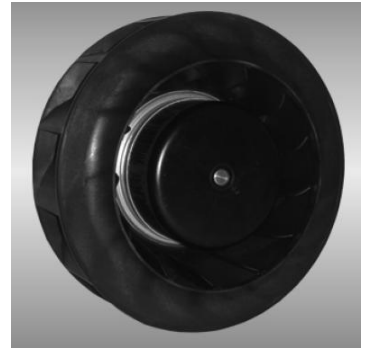

Ø190X69 mm



- Motor:** DC single phase brushless motor
- Material/Frame:** Die cast aluminum (94V-0);
- Impeller:** Plastic(94V-0)
- Bearing:** Two ball precision bearing
- Insulator class:** B
- Weight:** 1.0Kg(CDC),1.3kg(CDCM) / PC

Drawing

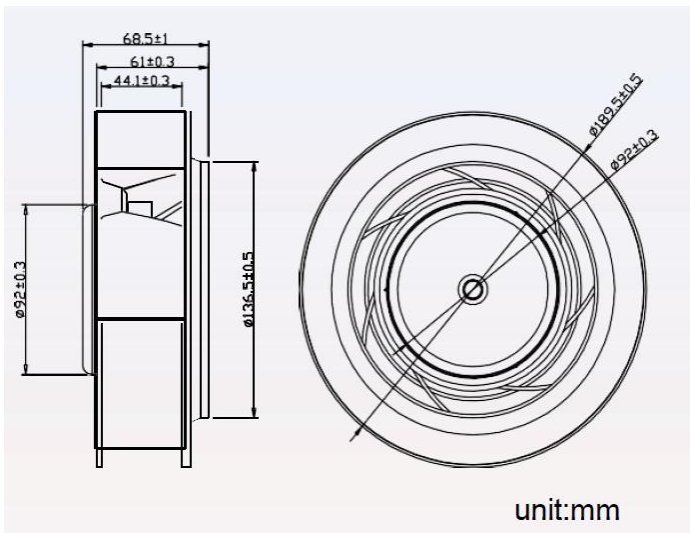

Characteristic Curves

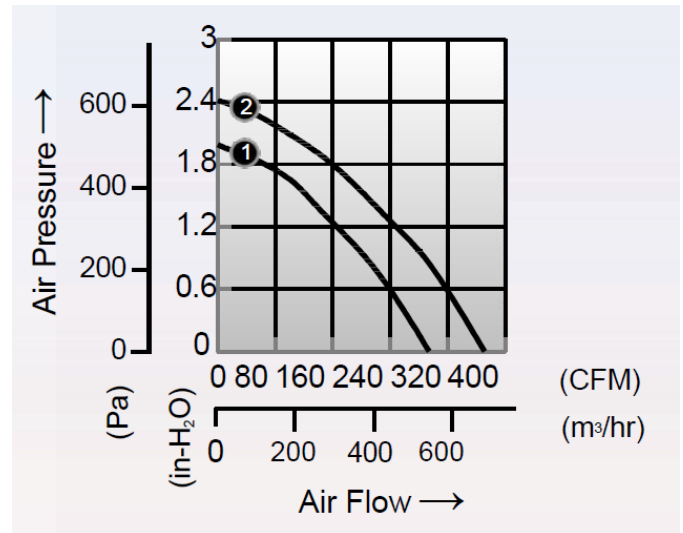

SPECIFICATION

Model	Voltage (V)	Current (A)	Speed (RPM)	Air Flow (CFM)	Pressure (in-H ₂ O)	Noise (dB)
CDC241969XB	24	3.5	3000	371	1.99	68
CDC481969XB	48	1.8	3000	371	1.99	68
CDCM241969XB	24	3.5	3000	294	2.41	73
CDCM481969XB	48	1.8	3000	294	2.41	73

DC Centrifugal Fan