



ø220X71 mm



- Motor:** DC single phase brushless motor
- Material/Frame:** Die cast aluminum (94V-0);
- Impeller:** Plastic(94V-0)
- Bearing:** Two ball precision bearing
- Insulator class:** B
- Weight:** 1.1Kg(CDC),1.4kg(CDCM) / PC

Drawing

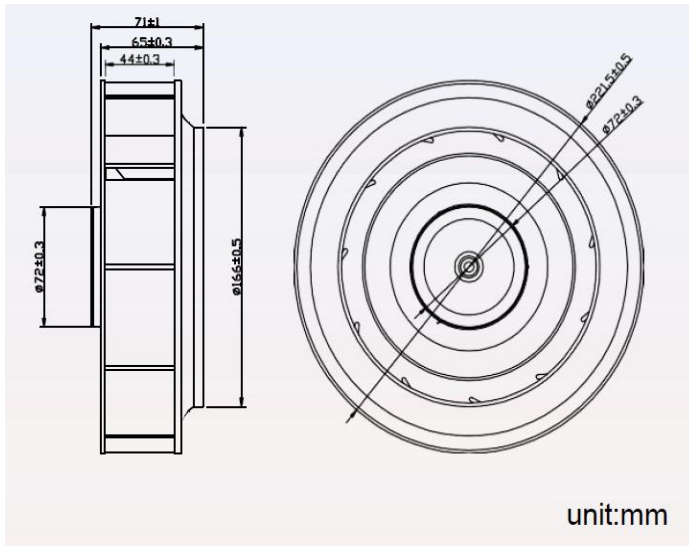

Characteristic Curves

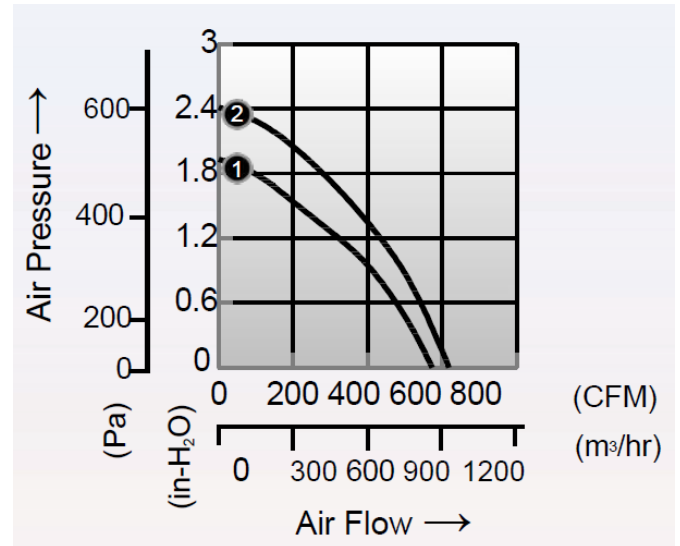

SPECIFICATION

Model	Voltage (V)	Current (A)	Speed (RPM)	Air Flow (CFM)	Pressure (in-H ₂ O)	Noise (dB)
CDC242271MB	24	4.5	2800	573	1.93	65
CDC482271MB	48	2.3	2800	573	1.93	65
CDC242271HB	24	4.5	3150	618	2.41	73
CDC482271HB	48	2.3	3150	618	2.41	73

DC Centrifugal Fan