



160x160x62 mm (6.3x6.3x2.4 in)



- Frame:** Die cast aluminum
- Impeller:** Plastic (UL 94V-0 P.B.T)
- Ambient Temperature Range:** -20°C ~ +70°C
- Operating Voltage Range:** Rated Voltage ±10%
- Bearing:** Ball bearing
- Motor Structure:** Capacitor induction
- Motor protection:** Thermally protected
- Termination:** Terminals or Lead wire
- Weight:** 1400g / PC

Dimension (units:mm)

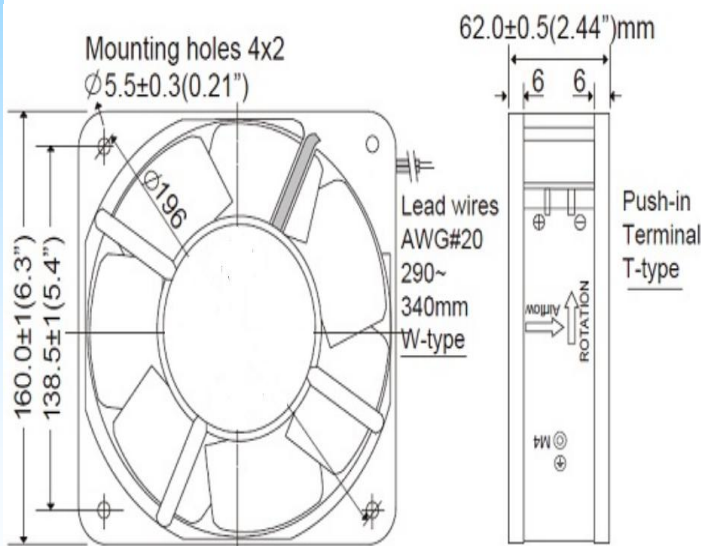

Characteristic Curves

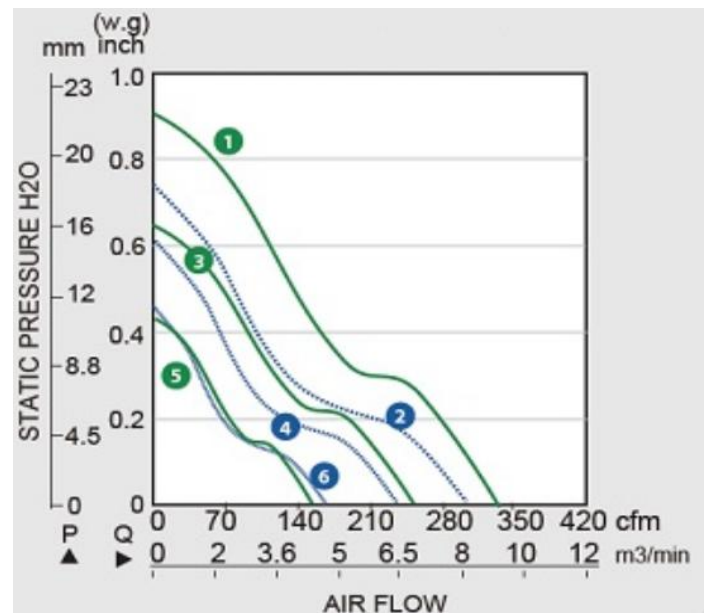

SPECIFICATION

Model	Voltage (V)	Freq. (Hz)	Power (W)	Speed (RPM)	Air Flow (CFM)	Pressure (mm Aq)	Noise (dB)
CY11662HB	115	50/60	48/55	2700/3100	298/340	19.3/23.62	56
CY21662HB	230	50/60	48/55	2700/3100	298/340	19.3/23.62	56