



□172x150x38 mm
 (□6.77x6x1.5 in)



Frame: Die cast aluminum

Impeller: Plastic

Ambient Temperature Range: -20°C ~ +70°C

Operating Voltage Range: Rated Voltage ±10%

Bearing: Ball (UL approval)

Motor Structure: AC Induction Capacitor Motor

Motor protection: Thermal Protected (Auto Restart) optional IP54, IP56, IP67

Termination: Terminals or Lead wire

Weight: 800g / PC

Dimension (units:mm)

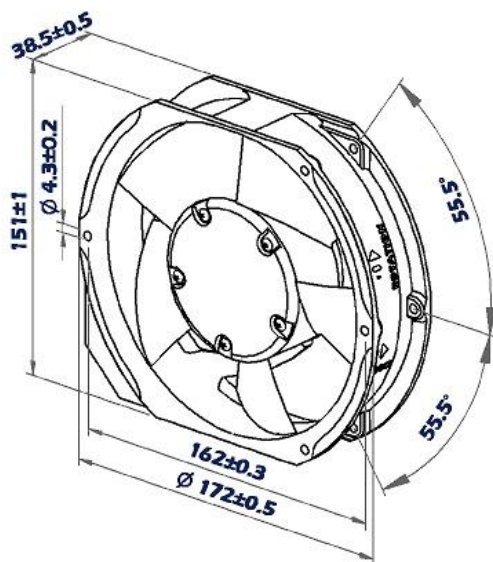

Characteristic Curves

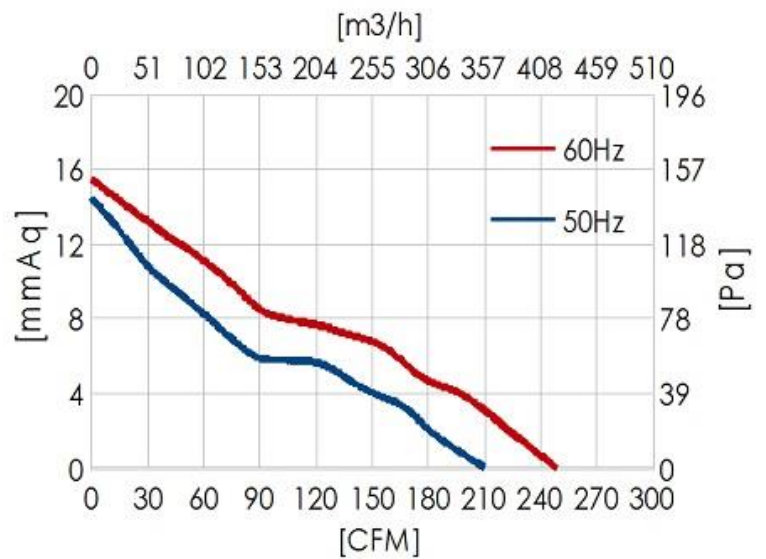

SPECIFICATION

Model	Voltage (V)	Freq. (Hz)	Current (A)	Power (W)	Speed (RPM)	Air Flow (CFM)	Pressure (mm Aq)	Noise (dB)	UL
CY11738HB	115	50/60	0.25/0.21	27/25	2700/3100	210/250	14/15.5	53/59	✓
CY21738HB	230	50/60	0.11/0.1	25/25	2700/3100	210/250	14/15.5	53/59	✓