



# 200x220x70 mm (7.87x8.66x2.55 in)



- Frame:** Die cast aluminum
- Impeller:** Plastic (UL 94V-0 P.B.T)
- Ambient Temperature Range:** -20°C ~ +70°C
- Operating Voltage Range:** Rated Voltage ±10%
- Bearing:** Ball bearing
- Motor Structure:** Capacitor induction
- Motor protection:** Thermally protected
- Termination:** Terminals or Lead wire
- Weight:** 2200g / PC

## Dimension (units:mm)

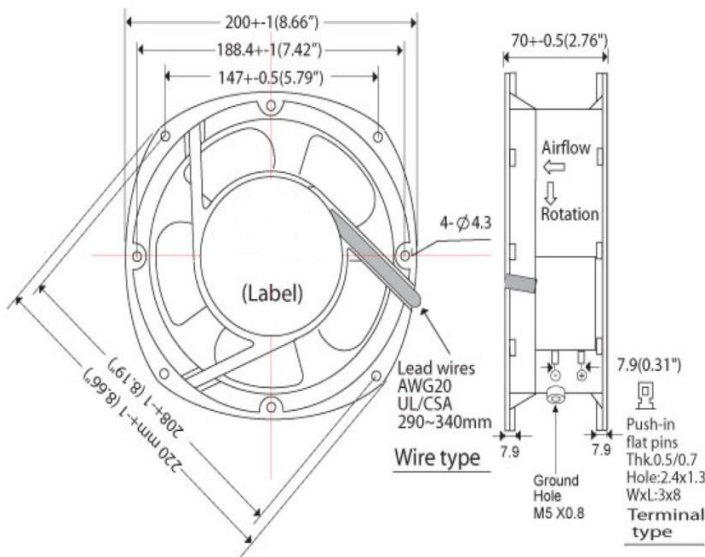

## Characteristic Curves

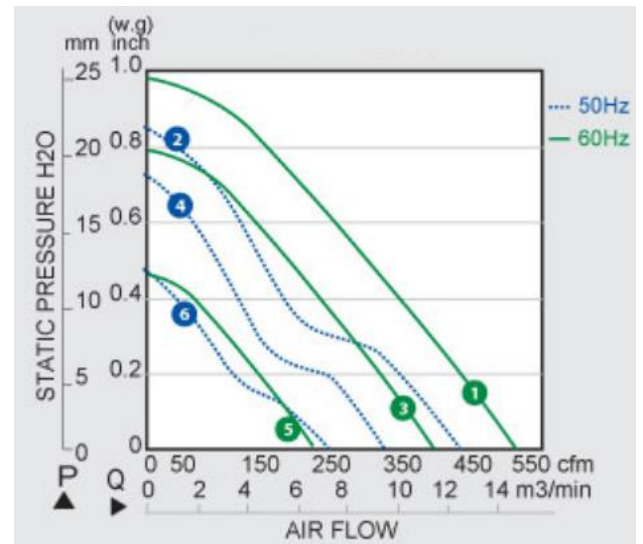

## SPECIFICATION

Model	Voltage (V)	Freq. (Hz)	Power (W)	Speed (RPM)	Air Flow (CFM)	Pressure (mm Aq)	Noise (dB)
CY12070HB	115	50/60	60/75	2800/3200	440/510	21.59/24.64	66
CY22070HB	230	50/60	60/75	2800/3200	440/510	21.59/24.64	66