



□ 254x89 mm



F Frame: Die cast aluminum

Impeller: Steel

Ambient Temperature Range: -10°C ~ +70°C

Motor Structure: DC Permanent Magnet Brushless

Motor protection: Locked Rotor Protection and Polarity Protection

Protection Grade: Insulation Class B, **IP54** option (IP67 rated)

Option: RD, FG, PWM/ 0-10 Speed control

Connection: Lead wire

Package: 2550g / PC

Dimension (units:mm)

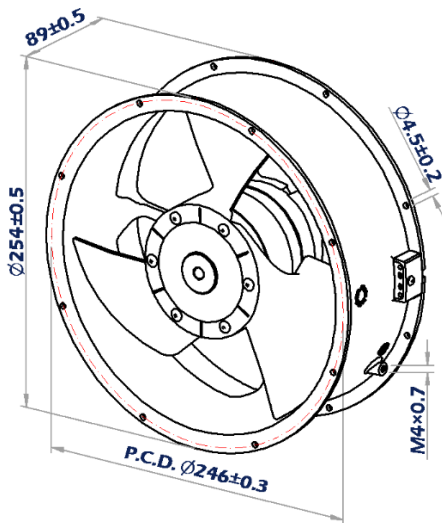

Characteristic Curves

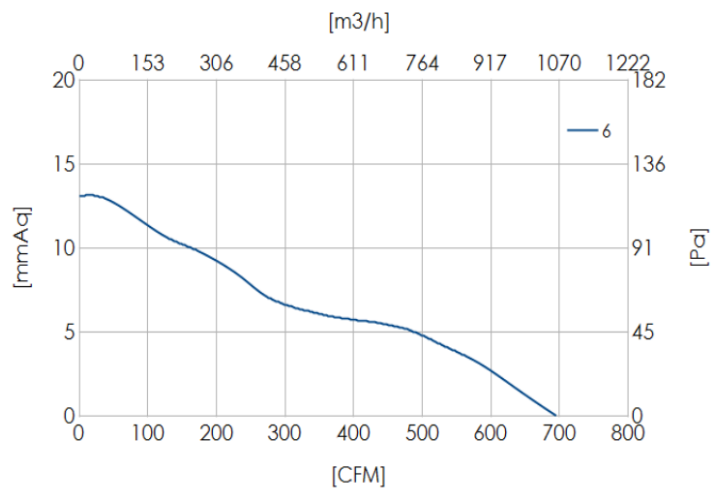

SPECIFICATION

Model	Voltage (V)	Current (A)	Speed (RPM)	Air Flow (CFM)	Pressure (mmAq)	Noise (dB)
CDM ^x 2589HB	24/48	2.02/1.36	2800	784	14.6	60

x: 12(12V),24(24V),48(48V)